

N-E Color Strip

User Manual

Contents

Safety Information	3
Technical Information	4
Main Power Connection	5
DMX 512 Connection	5
Rigging the Fixture	6
DMX Profile	6
Main Control	7
Cleaning & Maintenance	8



MEGA **LITE**

Check that the unit has not been damaged during transport



Read all cautions and warnings
prior to operation of this
equipment

Protection Against Fire



Fire

1. Maintain a minimum of 1 foot distance from any type of flame.
3. Replace fuse only with the specified type and rating.
4. Do Not install the unit too close to a heat source.
5. Make sure cables are properly secured away from unit movement.
6. Maximum surface operating temperature 80°.

Protection Against Fire



Electrical

1. Disconnect power before servicing.
2. For connection to main power supply proceed to page 5.
3. This unit must be earthed. (electronically grounded)
4. Do not expose unit to rain or moisture.

Protection Against Mechanical Hazards



Mechanical

1. Use safety chain when hanging unit.
2. Use quality clamps or bolts when positioning unit.
3. Do not open unit while it is on, risk of electrical shock.

Technical Information

Fixture

4050- N-E Color Strip

Mechanical Specifications

DMX Connectors: 3-pin XLR connectors

Power Connection: In/Out

Thermal: Maximum ambient temperature 40° C
Maximum surface temperature 60° C

Fastening System: Dual end mount

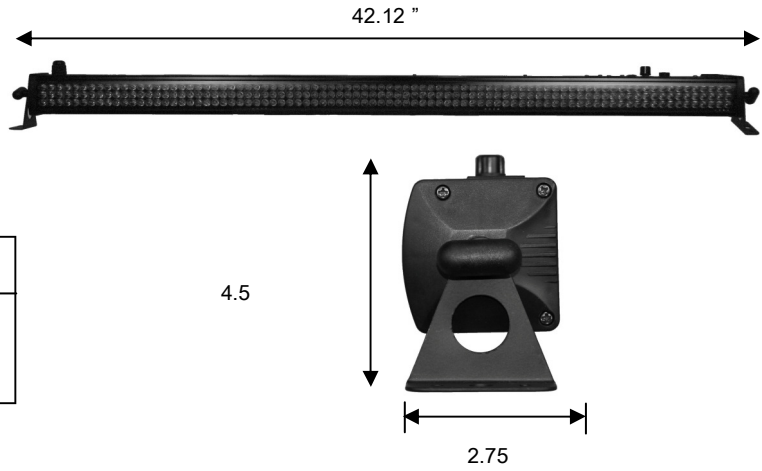

Fixture	Packaged for Shipping
Size: 42.12"L x 2.75"W x 4.5"H	Size: 42.5"L x 5"W x 5."H
Weight: 5 lbs	Weight: 6 lbs

Electrical Specifications

LED Quantity: 252

Red: 108
Green: 72
Blue: 72

LED Diameter: 10 mm

LED Lifetime: 60,000 to 100,000 hours

LED Angle: 35° (± 5°)

Power Consumption: 100 - 240V 50/60 Hz

Ballast: Electronic

Watts: 18.8

R(108)	281	21	8.8	4	2.3	LUX
G(72)	323	35	14	6.3	3.1	LUX
B(72)	541	58	20	10	5	LUX
RGB(252)	1115	110	41	20	10	LUX

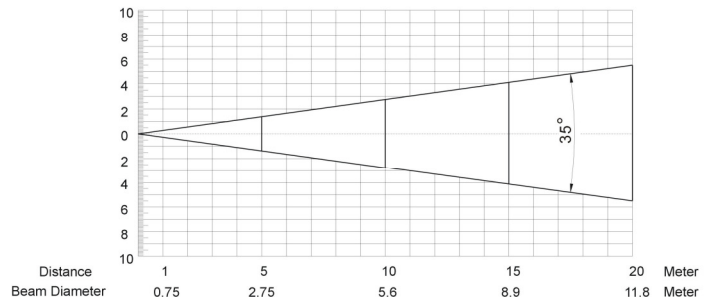

Control & Programming

Protocol: DMX 512

DMX Channels: 13 Channels

Control options: Audio-trigger

Operating mode: Master/Slave, Stand alone

Main Power Connection

Caution!

1. Do not connect fixture to a dimmer system.
2. This unit has Auto switching power supply. It will respond to 110V or 220V automatically
3. This unit must be earthed. (electronically grounded)
4. Replace fuse only with the specified type and rating.

The occupation of the connection-cable is as follows:

110V Connection

Cable (USA)	Cable (EU)	Pin	Connection
Black	Brown	Live	L
White	Light Blue	Neutral	N
Green	Yellow/Green	Ground	

220V Connection

Cable (USA)	Cable (EU)	Pin	Connection
Black	Brown	Live	L
White	Light Blue	Live	N
Green	Yellow/Green	Neutral	

DMX-512 Connection

The fixture is equipped with 3 pin XLR Sockets for DMX input and output. The sockets are wired in parallel. Only use a shielded twisted pair cable designed for RS-485 and 3 pin XLR plugs and connectors in order to connect the controller with the fixture or the fixture with another.

DMX—input

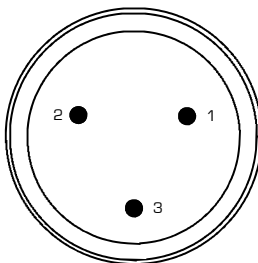

1. Shield
2. Signal (-)
3. Signal (+)

DMX—output

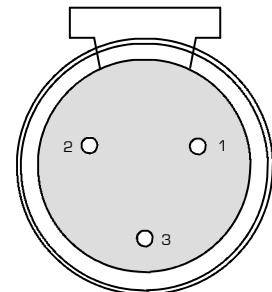

Caution!

At the last fixture the DMX signal needs to be terminated with a terminator. Solder a 120 Ohm resistor between the (-) and the (+) signal into a 3 pin XLR plug and plug it in to the last fixture on the signal run. Pre-manufactured terminator plugs are available for purchase from your Mega-Lite dealer (HOS-DMXT).

Rigging the fixture

Caution!

1. The installations must be carried out by an authorized dealer or trained professional.
2. Unit may cause severe injuries if you have doubts concerning the safety do not install.
3. Unit is to be 24 inches away from flammable materials (decoration material)
4. Use high quality installation equipment to hang unit.

When rigging a unit it is very important that you follow common safety procedures. Rigging requires extensive experience including but not limited to calculating working loads, material being used and periodic safety inspections. If you lack these qualifications, do not attempt the installation yourself, instead use a professional structural rigger.

When rigging the unit always be secured with a secondary safety attachment. The installation location of the projector has got to be built in the way that it can hold 10 times the weight for 1 hour with out any harming. Installation should be checked at least one time a year by a skilled person.

DMX Profile

N-E Color Strip DMX Profile (13 Channels)

DMX Channel	Function	Description	Value
1	Dimmer, Macro	Dimmer (Ch 2-13 dimmer valid)	0-10
		Strobe (Ch 1-13 Dimmer valid)	11-51
		Color Fade slow to fast	84-115
		Color Snaps slow to fast	116-123
		Color Chase (red, purple) slow to fast	124-139
		Color Chase (red, yellow) slow to fast	140-147
		Color Chase (green, aqua) slow to fast	148-155
		Color Chase (blue, purple) slow to fast	156-163
		Color Chase (blue, aqua) slow to fast	164-179
		Color Chase (purple, green) slow to fast	180-195
		Color Chase (yellow, blue) slow to fast	196-211
		Color Chase (aqua, red) slow to fast	212-227
		Color Chase 1 slow to fast	228-243
		Color Chase 2 slow to fast	244-251
Color Chase 3 slow to fast	252-255		
2	LED Color	Red full bar	0-255
3	LED Color	Green full bar	0-255
4	LED Color	Blue full bar	0-255
5	LED Color	Red 1st segment	0-255
6	LED Color	Green 1st segment	0-255
7	LED Color	Blue 1st segment	0-255
8	LED Color	Red 2nd segment	0-255
9	LED Color	Green 2nd segment	0-255
10	LED Color	Blue 2nd segment	0-255
11	LED Color	Red 3rd segment	0-255
12	LED Color	Green 3rd segment	0-255
13	LED Color	Blue 3rd segment	0-255

Main Control Menu

The control board on the fixture base is your interface to access and control all the functions on the unit. Its dipswitch interface gives you a code view of the options. The following will explain each function and its options.

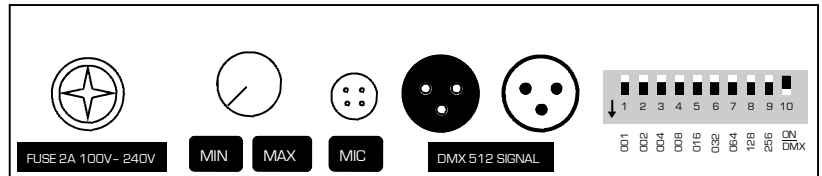

DMX Addressing

Turn dipswitch 10 to the **Down** position. Each dipswitch from 1 to 9 holds a numerical value located below the dipswitch. Add the numerical value to get the desired fixture start address channel. The user must assign a start address on the fixture that indicates the first channel reserved in the controller.

For example, if you wish the first unit to start on address channel 85 you will need to turn on dipswitch 1,3,5 and 7 ($1+4+16+64=85$)



Functions

Turn dipswitch 10 to the **UP** position. This function will turn on the functions that will allow the unit to run a preprogram function. Additionally, this unit may serve as a master unit where other units will copy its functions. To create a master unit connect the XLR cable from the output to the input on the next unit. And address the next unit as fixture 1.

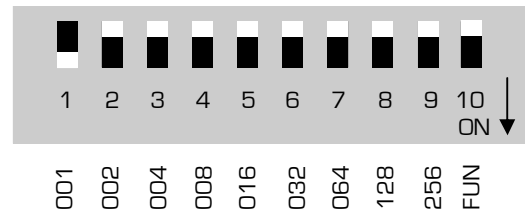

FUNCTION	1	2	3	4	5	6	7	8	9	10
RED	ON									
GREEN		ON								
BLUE			ON							
STROBE	SLOW	MID	FAST	FASTES	ON	CYAN	MAGENTA	YELLOW		
COLOR FADE	SLOW	MID	FAST	FASTES		ON				
COLOR SNAP	SLOW	MID	FAST	FASTES			ON			
CHASE LIGHT	SLOW	MID	FAST	FASTES				ON		
SOUND ACTIVATED	RAINBOW								ON	
DMX	1	2	4	8	16	32	64	128	256	ON

Cleaning and maintenance

Installation Maintenance: The operator has to make sure that the unit is operating safely and has the installations and electronics checked by an expert every 2 years.

The following points have to be considered during the inspection:

- 1) All screws used for installing the device or part of the device have to be tightly connected and must not be corroded.
- 2) There must not be any deformations on the housing, fixation and installation spots (ceiling, suspension, trussing).
- 3) The electronic power supply cables must not show any damages, material fatigue (e.g. porous cables) or sediments. Further instructions depending on the installation spot and usage have to be adhered by a skilled installer and any safety problems have to be removed.

Disconnect from mains before starting maintenance operation!



Caution Danger to life!

Electrical

We recommend a frequent cleaning of the device. Please use a moist, lint free cloth. Never use alcohol or solvents!

- 1) The plastic cover will require periodic cleaning on usage and environment. Environment with foggers will require more periodic cleaning as fog fluid tends to build up residues, reducing the light output.

Note: There is no serviceable parts inside the device except for the LED's. Maintenance and service operations are to be carried out by authorized dealers.

Replacing the fuse: Only replace the fuse with the same type and rating.

Replacing the power cable: If the power cable of this device becomes damaged, it has to be replaced by authorized dealers only in order to avoid hazards.

Should you have further questions , please contact your dealer.

Parts List

4050-gc	Plastic clear cover
4050-ec	Plastic end caps
4050-ledmod	LED module
4050-mainc	Main PCB card
4000-dmx	XLR Connections
4000-fh	Fuse Holder
4050-ps	Power Supply



Mega-Lite
5718 Kenwick St
San Antonio, TX 78238
Ph 210-684-2600 Fax 210-855-6279
www.mega-lite.com / info@mega-lite.com